

SFP+ 10G, 850nm, 300M, MULTIMODE SNX-8596-03D

Features:

- Up to 10.5 Gbps data rate
- 850nm VCSEL Laser and PIN photo detector
- Duplex LC receptacle optical interface compliant
- Single +3.3V power supply
- Hot-pluggable
- AC coupling of LVPECL signals
- International Class1 laser safety certified
- Operating temperature range:

Commercial: -5°C~70°C

Industrial: -40°C~85°C

- RoHS Compliant
- DDMI function available with internally calibrated mode



Application:

- 10G BASE-SR
- Fiber Channel

Standard:

- Compliant with SFP+ MSA
- Compliant with SFF-8472
- Compatible with IEEE802.3ae 10GBASE-SR
- 10GFC

Ordering Information

Part. No	Specifications					
	Package	Data Rate (Gbps)	Wavelength (nm)	Temperature (°C)	Reach (m)	DDM
SFP-SR	SFP+	10.3125	850	-5~70	300	Y
SFP-SR IT	SFP+	10.3125	850	-40~85	300	Y

Specification

Absolute Maximum Ratings				
Parameter	Symbol	Min	Max	Unit
Storage temperature	TS	-40	85	°C
Power Supply Voltage	Vcc	-0.5	+4	V
Relative Humidity	RH	5	95	%

Recommended Operating Conditions					
Parameter	Symbol	Min	Typical	Max	Unit
Operating Case Temperature (Commercial)	Tc	-5		70	°C
Operating Case Temperature (Industrial)		-40		85	
Power Supply Voltage	Vcc	3.135	3.3	3.465	V
Supply Current	Icc			250	mA
Data Rate		1	10.3125	10.5	Gbps
Fiber Length 50µm core MMF (2000MHz-km)		-		300	M

Electrical Characteristics						
Parameter	Symbol	Min	Typical	Max	Unit	Notes
Transmitter differential input voltage		180		700	mV	
Receiver differential output Voltage		300		850	mV	
Transmit Fault (TX_Fault)	Voh	2		Vcc	V	LVTTTL
	Vol	0		0.8	V	LVTTTL
Loss of Signal (LOS)	Voh	2		Vcc	V	LVTTTL
	Vol	0		0.8	V	LVTTTL
TX Disable	Vih	2		Vcc	V	LVTTTL
	Vil	0		0.8	V	LVTTTL

Optical transmitter Characteristics						
Parameter	Symbol	Min	Typical	Max	Unit	Notes
Launched Power (avg.)	P _{out}	-6		-1	dBm	
Operating Wavelength Range	λ _c	840	850	860	nm	
Spectral Width	Δλ			0.45	nm	
Extinction Ratio	ER	3.5			dB	2
Relative Intensity Noise	RIN			-128	dB/Hz	
Optical Rise/Fall Time	Tris/Tfall	28		50	Ps	3
Transmitter and Dispersion Penalty	TDP			3.2	dB	
Optical Tx Output disable	P _{dis}			-45	dBm	
Output Eye Diagram	Complies with IEEE802.3ae eye masks when filtered					
Optical receiver Characteristics						
Parameter	Symbol	Min	Typical	Max	Unit	Notes
Receiver Sensitivity	S			-10	dBm	4
Wavelength Range	λ _c	840		860	nm	
Receiver Reflectance				-12	dB	
Optical Power Input Overload	P _{in-max}	0.5			dBm	4
LOS	Optical De-assert	P _d		-13	dBm	4
	Optical Assert	P _a	-30			
LOS hysteresis		0.5		5	dB	5

Note1. The supply current is SFP+ module's working current.

Note2. For the measurements, the device was driven with 2³¹-1 PRBS pattern

Note3. Optical transition time is the time interval required for the rising or falling edge of an optical pulse to transition between the 20% and 80% amplitudes relative to the logical 1 and 0 levels.

Note4. Measured with a PRBS 2³¹-1 test pattern, @10.3125Gbps, ER=4dB, BER<10⁻¹²

Note5. The LOS Hysteresis minimizes 'chatter' on the output line. In principle, Hysteresis alone does not guarantee chatter-free operation.

Digital Diagnostic Monitoring Information

Parameter	Accuracy	Calibration	Note
Temperature	±3°C	internal	-5~75
Voltage	±3%	internal	V _{cc} =3.3V±5%
Bias Current	±10%	internal	Specified by normal value
TX Power	±3dB	internal	-6~-1dBm
RX Power	±3dB	internal	-14~-1dBm

Pin definition

The SFP+ modules are hot-pluggable. Hot pluggable refers to plugging in or unplugging a module while the host board is powered. The SFP+ host connector is a 0.8 mm pitch 20 position right angle improved connector specified by SFF-8431, or stacked connector with equivalent with equivalent electrical performance. Host PCB contact assignment is shown in Figure 1 and contact definitions are given in Table 5. SFP+ module contacts mates with the host in the order of ground, power, followed by signal as illustrated by Figure 2 and the contact sequence order listed in the table.

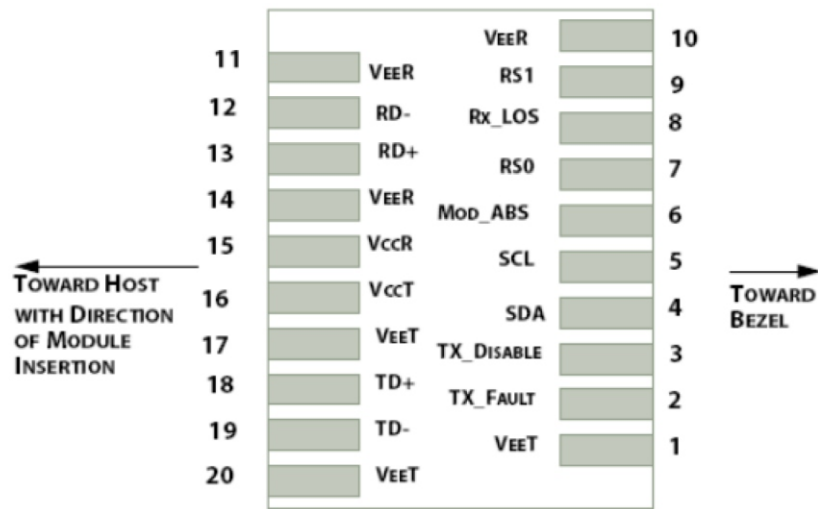

Figure 1 SFP+ Pad assignment Top View

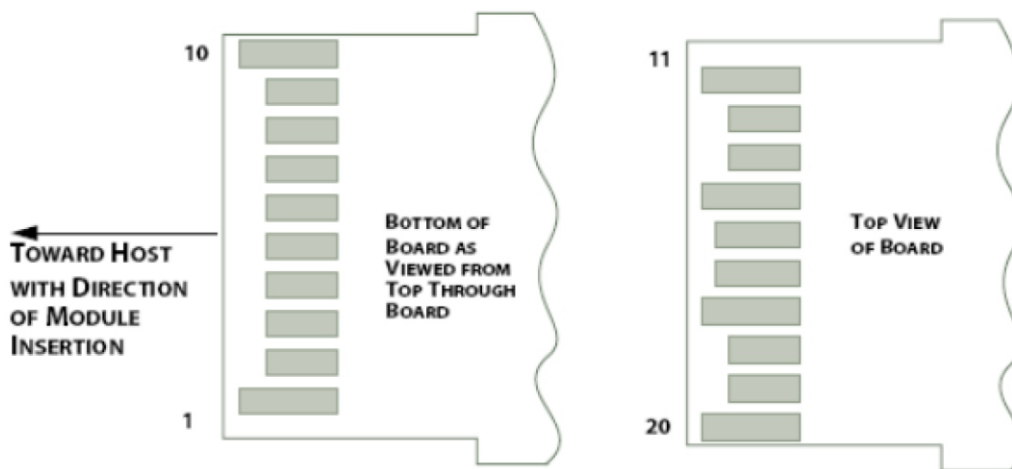

Figure 2 SFP+ Module Contact Assignment

Pin	Symbol	Name/Description	Power Seq.	Ref.
1	VeeT	Transmitter Ground (Common with Receiver Ground)	1st	1
2	TX_Fault	Transmitter Fault, Low: normal; High: abnormal	3rd	2
3	TX_Disable	Transmitter Disable High: Transmitter off Low: Transmitter on	3rd	3
4	SDA	2-Wire Serial Interface Data Line (Same as MOD-DEF2 in INF-8074i)	3rd	4
5	SCL	2-Wire Serial Interface Data Line (Same as MOD-DEF2 in INF-8074i)	3rd	4
6	Mod_ABS	Module Absent, Connect to VeeT or VeeR in Module	3rd	5
7	RS0	Rate Select 0, optionally controls SFP+ module receiver	3rd	6
8	RX_LOS	Receiver Loss of Signal indication High: loss of signal Low: signal detected	3rd	7
9	RS1	Rate Select 1, optionally controls SFP+ module transmitter	3rd	8
10	VeeR	Receiver Ground	1st	1
11	VeeR	Receiver Ground	1st	1
12	RD-	Receiver Inverted DATA out. AC Coupled. CML-O	3rd	9
13	RD+	Receiver Non-inverted DATA out. AC Coupled. CML-O	3rd	9
14	VeeR	Receiver Ground	1st	1
15	VccR	Receiver Power Supply	2nd	10
16	VccT	Transmitter Power Supply	2nd	10
17	VeeT	Transmitter Ground	1st	1
18	TD+	Transmitter Non-Inverted DATA in. AC Coupled. CML-I	3rd	11
19	TD-	Transmitter Inverted DATA in. AC Coupled. CML-I	3rd	11
20	VeeT	Transmitter Ground	1st	1

SFP+ Module PIN Definition

Power Seq.: Pin engagement sequence during hot plugging.

Note1. The module signal ground contacts.

Note2. This pin is an open drain/collector and should be pulled up to Vcc-host in the host with a 4.7k~10k Ohm resistor.

Note3. This pin should be pulled up to Vcct with a 4.7k~10k Ohm resistor in modules.

Note4. SDA&SCL (IIC) are needed pull up 4.7k~10k Ohm resistors on host board.

Note5. Mod_ABS is connected to VeeT or VeeR in the SFP+ module.

Note6. Rate Select 0,Optionally controls SFP+ module receiver , High: RX input signaling rate >4.25GBd and Low: RX input signaling rates ≤4.25GBd.

Note7. Module RX_Los of signal indication need pull up 4.7k~10k Ohm resistor on host board.

Note8. Rate Select 1,Optionally controls SFP+ module transmitter, High: Tx input signaling rate >4.25GBd and Low : Tx input signaling rates ≤4.25GBd.

Note9. RD -/+ : These are the differential receiver outputs. They are CML AC-coupled with 100 Ohm terminal resistor matching internal.

Note10. VccR and VccT are the receiver and transmitter power supplies.

Note11. TD -/+ : These are the differential transmitter inputs. They are CML AC-coupled with 100 Ohm terminal resistor matching internal.

Digital Diagnostic Memory Map

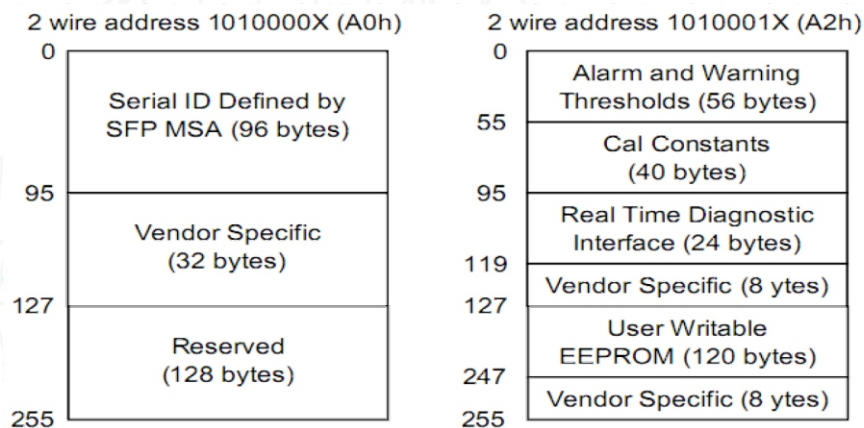

EEPROM Serial ID Memory Contents

The optical transceiver contains an EEPROM. It provides access to sophisticated identification information that describes the transceiver's capabilities, standard interfaces, manufacturer, and other information. When the serial protocol is activated, the host generates the serial clock signal (SCL, Mod Def 1). The positive edge clocks data into those segments of the EEPROM that are not writing protected within the SFP transceiver. The negative edge clocks data from the SFP transceiver. The serial data signal (SDA, Mod Def 2) is bi-directional for serial data transfer. The host uses SDA in conjunction with SCL to mark the start and end of serial protocol activation. The memories are organized as a series of 8-bit data words that can be addressed individually or sequentially.

The Module provides diagnostic information about the present operating conditions. The transceiver generates this diagnostic data by digitization of internal analog signals. Calibration and alarm/warning threshold data is written during device manufacture. Received power monitoring, transmitted power monitoring, bias current monitoring, supply voltage monitoring and temperature monitoring all are implemented. The diagnostic data are raw A/D values and must be converted to real world units using calibration constants stored in EEPROM locations 56 – 95 at wire serial bus address A2h. The digital diagnostic memory map specific data fields define as following.

EEPROM Serial ID Memory Contents (2-Wire Address A0h)

Address	Name of field	Hex	Description
BASE ID Fields			
00	Identifier	03	SFP transceiver

01	Ext. Identifier	04	Serial ID module supported for SFP
02	Connector	07	LC
03-05	Transceiver Codes	00 00 00	Not defined
06	Transceiver Codes	00	Not defined
07-10	Transceiver Codes	00 00 00	Not defined
11	Encoding	06	Encoding codes
12	BR, Nominal	67	10.3Gbps
13	Rate Identifier	00	Not defined
14	Length(9um)-km	00	Transceiver transmit distance
15	Length(9um)-m	00	
16	Length(50um)	08	
17	Length(62.5um)	03	
18	Length(cable)	00	Not support cable
19	Length(OM3)	1E	
20-35	Vendor Name	xx xx...xx	ASCII character
36	Reserved	00	Not defined
37-39	Vendor OUI	00 00 00	Not defined
40-55	Vendor P/N	xx xx...xx	
56-59	Vendor P/N Rev.	41 30 20 20	"A0"(ASCII character)
60-61	Laser Wavelength	03 92	850nm
62	Reserved	00	Not defined
63	CC_BASE	xx	Check sum of bytes 0-62
Extended ID Fields			
64-65	Options	00 1A	RX_LOS、TX_Fault are implemented
66	BR, max	14	Upper bit rate margin,20%
67	BR, min	14	Lower bit rate margin,20%
68-83	Vendor SN	xx xx...xx	Vendor Serial Number in ASCII character
84-91	Date Code	xx xx...xx	Vendor Date Code in ASCII character
92	Diagnostic Monitoring Type	68	Digital Diagnostic monitoring implemented "External calibrated " is implemented, RX measurement type is "Average Power"
93	Enhanced options	F0	Optional Alarm/warning flags, soft Tx_Fault monitoring, soft LOS monitoring are implemented
94	SFF-8472 compliant	05	SFF-8472 compliant with revision 11.0
95	CC-EXT	xx	Check sum of bytes 64-94
Vendor Specific ID Field			
96-127	Vendor Specific	00	Vendor specific EEPROM
128-255	Reserved	00	Reserved for future use

Digital Diagnostic Monitoring Interface: Alarm and Warning Thresholds (2-Wire Address A2h)

Address	#Bytes	Name	Real Value	Unit	Hex
00-01	2	Temp High Alarm	85	°C	
02-03	2	Temp Low Alarm	-10	°C	
04-05	2	Temp High Warning	80	°C	
06-07	2	Temp Low Warning	-5	°C	
08-09	2	Voltage High Alarm	3.6	V	
10-11	2	Voltage Low Alarm	3	V	
12-13	2	Voltage High Warning	3.5	V	
14-15	2	Voltage Low Warning	3.0	V	
16-17	2	Bias High Alarm	20	mA	
18-19	2	Bias Low Alarm	1	mA	
20-21	2	Bias High Warning	15	mA	
22-23	2	Bias Low Warning	1.5	mA	
24-25	2	TX Power High Alarm	0	dBm	
26-27	2	TX Power Low Alarm	-6	dBm	
28-29	2	TX Power High Warning	-1	dBm	
30-31	2	TX Power Low Warning	-5	dBm	
32-33	2	RX Power High Alarm	0	dBm	
34-35	2	RX Power Low Alarm	-13	dBm	
36-37	2	RX Power High Warning	-1	dBm	
38-39	2	RX Power Low Warning	-12	dBm	
40-55	16	Reserved	Reserved		

Package Outline

Dimensions are in millimeters. All dimensions are $\pm 0.1\text{mm}$ unless otherwise specified. (Unit: mm)

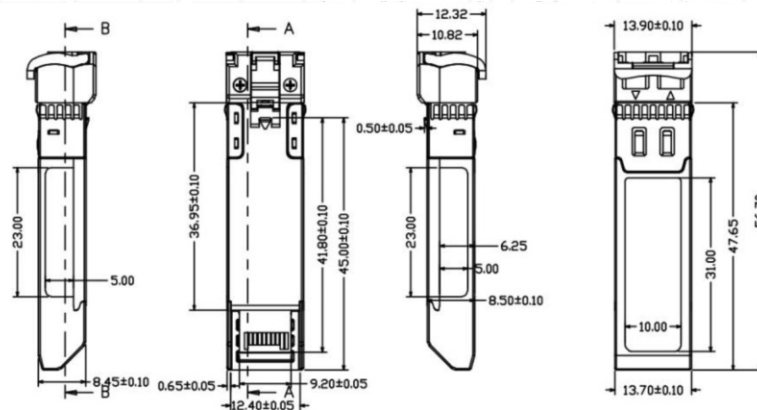

TOLERANCE LEVEL	
X.	± 0.2
.X	± 0.1
.XX	± 0.05
.XXX	± 0.02

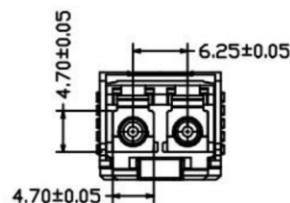

SFP-ZR

Regulatory Compliance

Feature	Test	Method
Electrostatic Discharge (ESD) to the Electrical Pins	MIL-STD-883E Method 3015.7	Class 1(>1000V for SFI pins, >2000V for other pins.)
Electrostatic Discharge (ESD) Immunity	IEC61000-4-2	Class 2(>4.0kV)
Electromagnetic Interference (EMI)	CISPR22 ITE Class B FCC Class B CENELEC EN55022 VCCI Class 1	Comply with standard
Immunity	IEC61000-4-3	Comply with standard
Eye Safety	FDA 21CFR 1040.10 and 1040.11 EN (IEC) 60825-1,2	Compatible with Class I laser Product

SFP-ZR